

PROJECT:

7110 Dillon Drive
Magnolia, TX. 77354.

REV.: DATE: DESCRIPTION:

12/22/13 FOR PERMITS



1 FRONT ELEVATION
1/4"=1'-0"

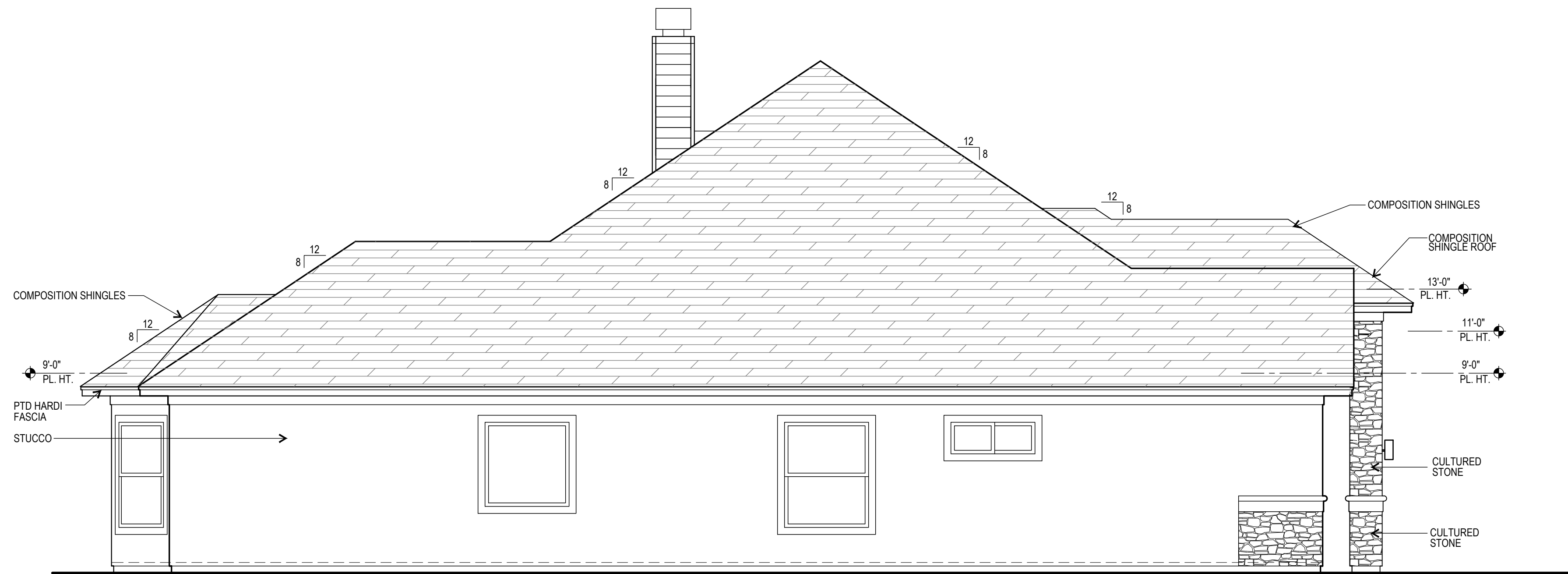

2 LEFT ELEVATION
1/4"=1'-0"



P.O. Box 131326
Spring, Texas 77389
210.336.5225 Mobile
281.789.7740 Phone
avalenciadesigngroup@gmail.com

© GLOBAL SKETCH GROUP
2012. ALL RIGHTS RESERVED.

The designers of GlobalSketchGroup are not, and do not represent to be, licensed architects. The designation Professional Building Designer (PBD) does not confer or imply any legal status in the State of Texas as a "registered professional". In Texas the practice of Commercial and Residential Design by a designer who is not a licensed architect is limited and permitted by exemptions to the Architect statute Chapter 1051. The building design works depicted herein are the sole property of GlobalSketchGroup and may not be constructed or used without its express written permission. No permission to modify or reproduce any of these building design works, including without limitation the construction of any building, is expressed or should be implied from delivery of preliminary drawings or unsealed construction drawings. Permission to construct the building depicted in sealed construction drawings is expressly conditioned on the full and timely payment of all fees otherwise due GlobalSketchGroup and, in the absence of any written agreement to the contrary, is limited to a one-time use on the site indicated on these plans.

SHEET TITLE:

EXTERIOR ELEVATIONS

SHEET NO:

A3.0

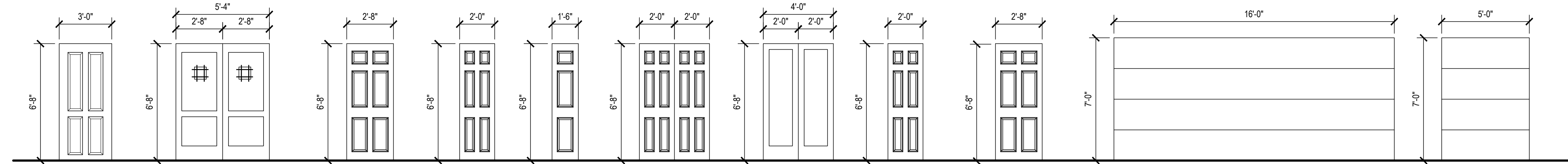

1 3/4" SOLID CORE EXTERIOR DOOR 1 3/4" SOLID CORE EXTERIOR DOOR W/ VISION PANEL 1 3/8" H.C. MASONITE INTERIOR DOOR 1 3/8" H.C. MASONITE INTERIOR DOOR 1 3/8" H.C. MASONITE INTERIOR DOOR 1 3/8" H.C. MASONITE INTERIOR DOOR 1 3/4" SOLID CORE INTERIOR DOOR W/ VISION PANEL 1 3/8" H.C. MASONITE INTERIOR POCKET DOOR 1 3/4" S.C. WOOD FIRE RATED DOOR 20 MIN. FIRE RATED DOOR W/ SELF CLOSER METAL SECTIONAL GARAGE DOOR

2 DOOR TYPES
1/4"=1'-0"

ALL EXTERIOR DOORS SHALL MAINTAIN THE FOLLOWING EFFICIENCY REQUIREMENTS:
1. MAXIMUM U-FACTOR = .35
2. AIR INFILTRATION (SLIDERS) = .3 CFM/SQ FT
3. AIR INFILTRATION (SWINGING) = .5 CFM/SQ FT

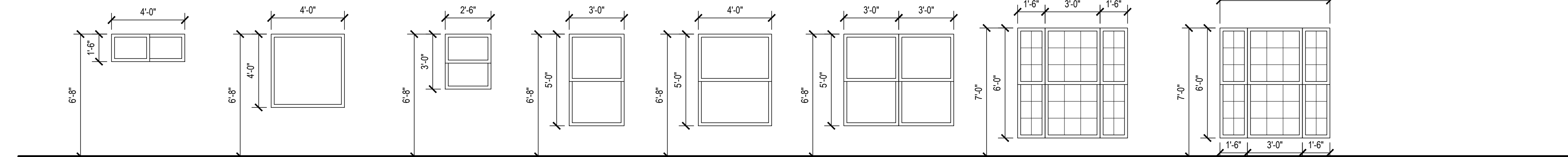

ALUMINUM FIXED WINDOW INSULATED SAFETY GLASS ALUMINUM FIXED OBSCURED TEMPERED WINDOW INSULATED SAFETY GLASS ALUMINUM FIXED HUNG WINDOW INSULATED GLASS ALUMINUM FIXED HUNG WINDOW INSULATED GLASS ALUMINUM FIXED HUNG WINDOW INSULATED GLASS ALUMINUM FIXED HUNG WINDOW INSULATED GLASS ALUMINUM FIXED HUNG WINDOW INSULATED GLASS ALUMINUM FIXED HUNG WINDOW INSULATED GLASS ALUMINUM FIXED HUNG WINDOW INSULATED GLASS

1 WINDOW TYPES
1/4"=1'-0"

ALL WINDOWS SHALL MAINTAIN THE FOLLOWING EFFICIENCY REQUIREMENTS:
1. MAXIMUM U-FACTOR = .75
2. MAXIMUM SHGC = .40
3. MAXIMUM AIR INFILTRATION = .3 CFM/SQ FT

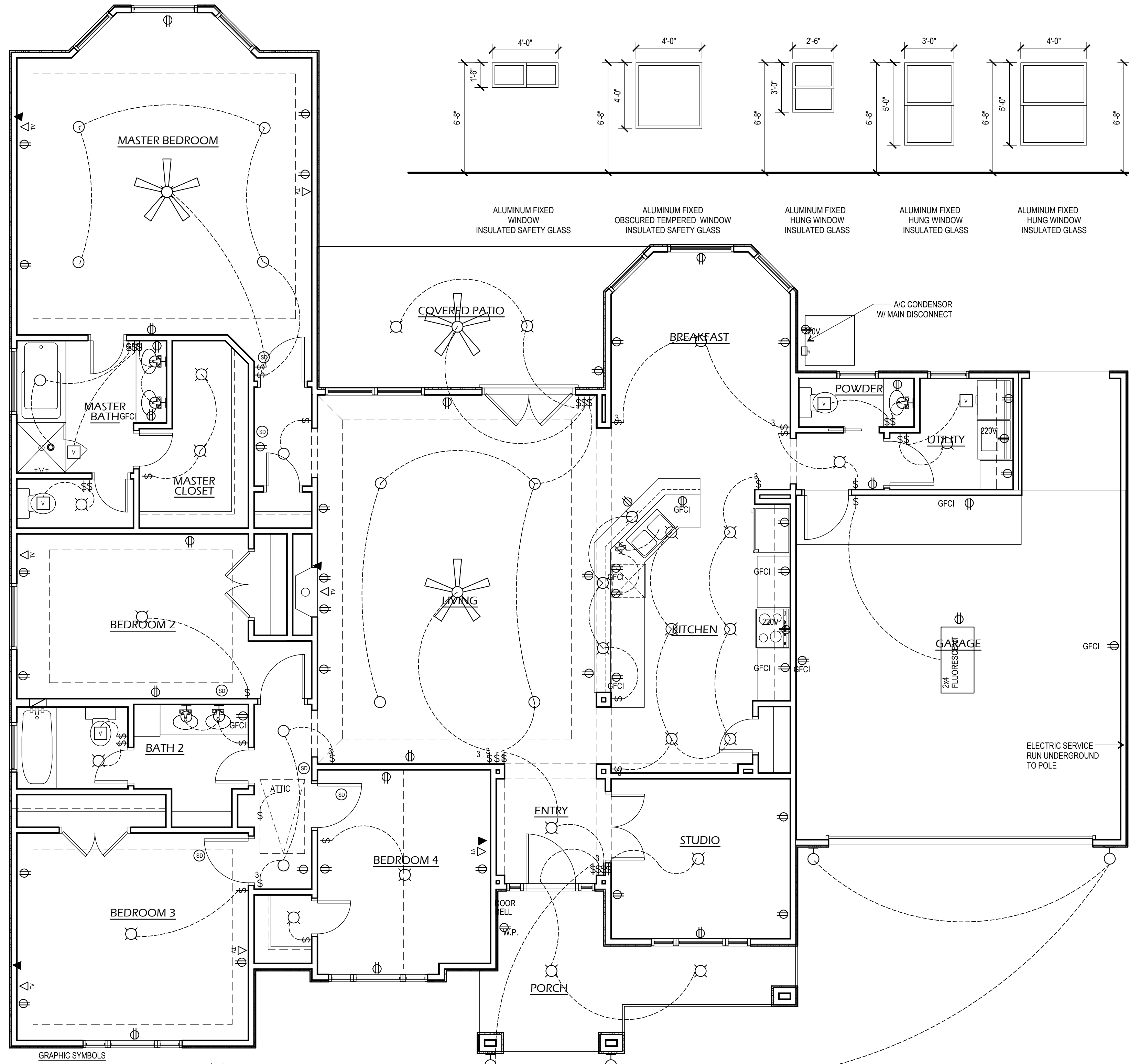

2 LIGHTING/POWER PLAN
1/4"=1'-0"

- GRAPHIC SYMBOLS
- ⊕ DUPLEX RECEPTACLE
 - ⊕ 220V DUPLEX RECEPTACLE 220V
 - ⊕ SINGLE POLE SWITCH
 - ▲ TELEPHONE JACK
 - △ CABLE TELEVISION OUTLET
 - ⊕ EXHAUST VENT
 - ⊙ CEILING MOUNTED LIGHT
 - ⊙ PENDANT LIGHT
 - ⊙ WALL MOUNTED LIGHT
 - ⊙ RECESSED LIGHT
 - ⊙ MAIN DISCONNECT
 - ⊙ SMOKE DETECTORS REQUIRE 110V CONNECTION TO HOUSE WIRING, BATTERY BACKUP, AND ALL HAVE TO BE INTERCONNECTED.

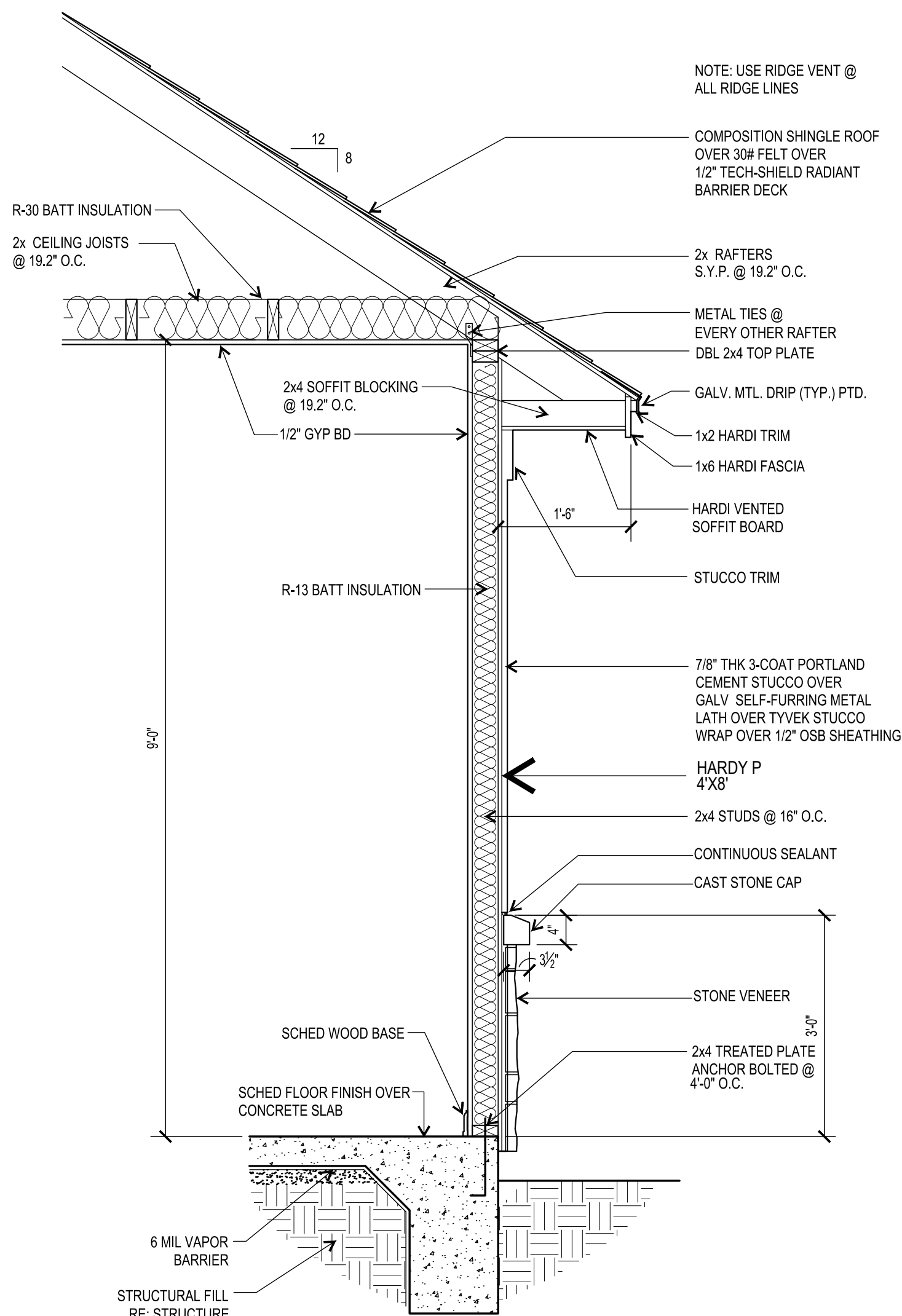

3 TYPICAL WALL SECTION
3/4"=1'-0"



P.O. Box 131326
Spring, Texas 77389
210.336.5225 Mobile
281.789.7740 Phone
avalienciadesigngroup@gmail.com

© GLOBAL SKETCH GROUP
2012. ALL RIGHTS RESERVED.

The designers of GlobalSketchGroup are not, and do not represent to be, licensed architects. The designation Professional Building Designer (PBD) does not confer or imply any legal status in the State of Texas as a "registered professional". In Texas the practice of Commercial and Residential Design by a designer who is not a licensed architect is limited and permitted by exemptions to the Architect statute Chapter 1051. The building design works depicted herein are the sole property of GlobalSketchGroup and may not be constructed or used without its express written permission. No permission to modify or reproduce any of these building design works, including without limitation the construction of any building, is expressed or should be implied from delivery of preliminary drawings or unsealed construction drawings. Permission to construct the building depicted in sealed construction drawings is expressly conditioned on the full and timely payment of all fees otherwise due GlobalSketchGroup and, in the absence of any written agreement to the contrary, is limited to a one-time use on the site indicated on these plans.

SHEET TITLE:

WALL SECTION
WINDOW TYPES
DOOR TYPES
LIGHTING AND POWER PLAN

SHEET NO.:

PROJECT:

7110 Dillon Drive
Magnolia, TX. 77354.

REV.: DATE: DESCRIPTION:

12/22/13 FOR PERMITS

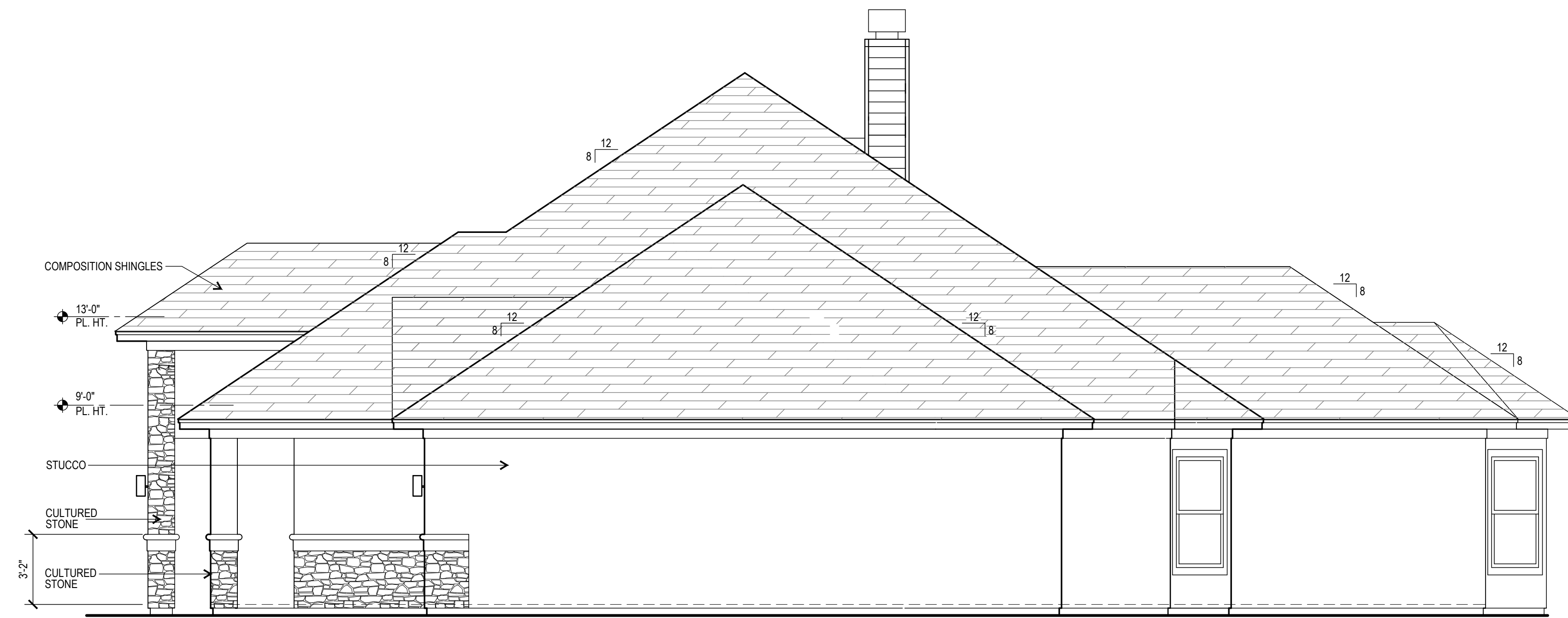

3 RIGHT ELEVATION
1/4"=1'-0"



4 REAR ELEVATION
1/4"=1'-0"



P.O. Box 131326
Spring, Texas 77389
210.336.5225 Mobile
281.789.7740 Phone
avalenciadesigngroup@gmail.com

© GLOBAL SKETCH GROUP
2012. ALL RIGHTS RESERVED.

The designers of GlobalSketchGroup are not, and do not represent to be, licensed architects. The designation Professional Building Designer (PBD) does not confer or imply any legal status in the State of Texas as a "registered professional". In Texas the practice of Commercial and Residential Design by a designer who is not a licensed architect is limited and permitted by exemptions to the Architect statute Chapter 1051. The building design works depicted herein are the sole property of GlobalSketchGroup and may not be constructed or used without its express written permission. No permission to modify or reproduce any of these building design works, including without limitation the construction of any building, is expressed or should be implied from delivery of preliminary drawings or unsealed construction drawings. Permission to construct the building depicted in sealed construction drawings is expressly conditioned on the full and timely payment of all fees otherwise due GlobalSketchGroup and, in the absence of any written agreement to the contrary, is limited to a one-time use on the site indicated on these plans.

SHEET TITLE:

EXTERIOR ELEVATIONS

SHEET NO:

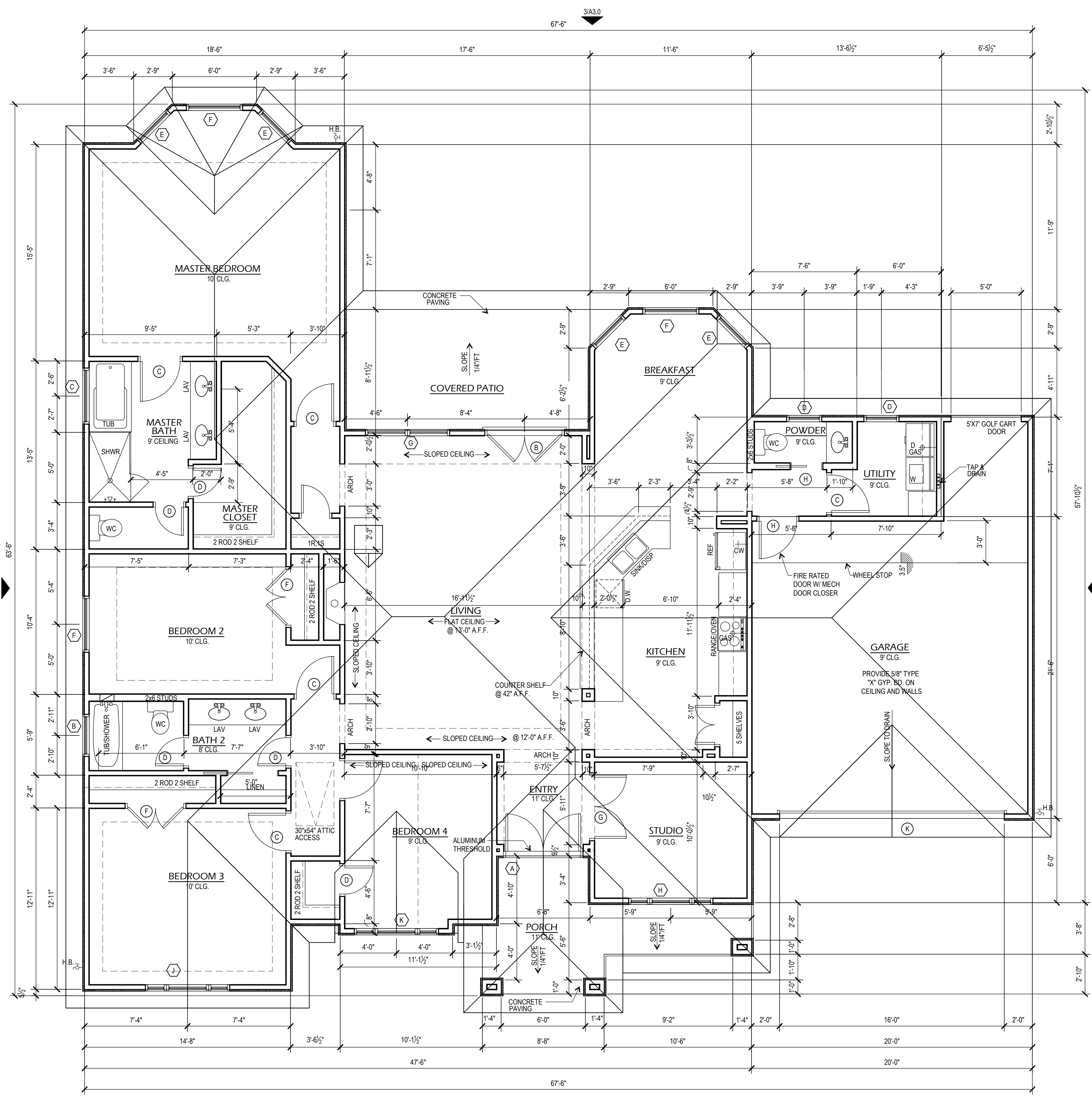

GENERAL NOTES:

- ALL DIMENSIONS ARE TO FACE OF STUDS.
- ALL PARTITIONS TO BE 2X4 @16" O.C. WITH 1/2" THK GYP BD UNLESS NOTED OTHERWISE. PROVIDE 5/8" THK TYPE "X" GYP BD ON WALLS AND CEILING AT GARAGE. PROVIDE "DURROCK" CEMENT BD AT ALL WET WALLS INCLUDING KITCHEN AND BATHROOMS.
- ALL ROOMS TO HAVE PTD WALLS AND CEILINGS.
- LOCATE WATER HEATER IN ATTIC OVER PARTITION. SET IN METAL PAN W/ DRAIN TO OUTSIDE.
- ALL INTERIOR DOORS TO BE 1 3/8" H.C. ON WOOD FRAME.
- ALL EXTERIOR DOORS TO BE 1 3/4" S.C. ON WOOD FRAME.
- ALL WINDOWS TO BE VINYL. SIZE AND PATTERN INDICATED ON PLANS.

- SMOKE DETECTORS REQUIRE 110V CONNECTION TO HOUSE WIRING. BATTERY BACKUP, AND ALL HAVE TO BE INTERCONNECTED.
- ALL BATH VENT FANS ARE TO TERMINATE AT EXTERIOR.
- PROVIDE WOOD BLOCKING AT ALL BEDROOMS AND LIVING ROOM FOR CEILING FAN INSTALLATION.
- ATTIC ACCESS STAIR TO BE 30"x54" AND HAVE A LOAD CAPACITY OF NOT LESS THAN 350 POUNDS.
- ALL GUARDRAILS & HANDRAILS SHALL WITHSTAND 200 LBS. IN ANY DIRECTION AT TOP.
- EXTENDED KITCHEN UP FLUSH WITH CEILING.

2 FLOOR PLAN
1/4"=1'-0"

SQUARE FOOTAGE CALCULATION

LIVING SPACE	2,280 s.f.
GARAGE SPACE	476 s.f.
FRONT PORCH	116 s.f.
COVERED PATIO	154 s.f.
TOTAL	3,026 s.f.

GRAPHIC SYMBOLS

- (G) WINDOW TYPE
- (A) DOOR TYPE
- (1/A3.0) EXTERIOR ELEVATION

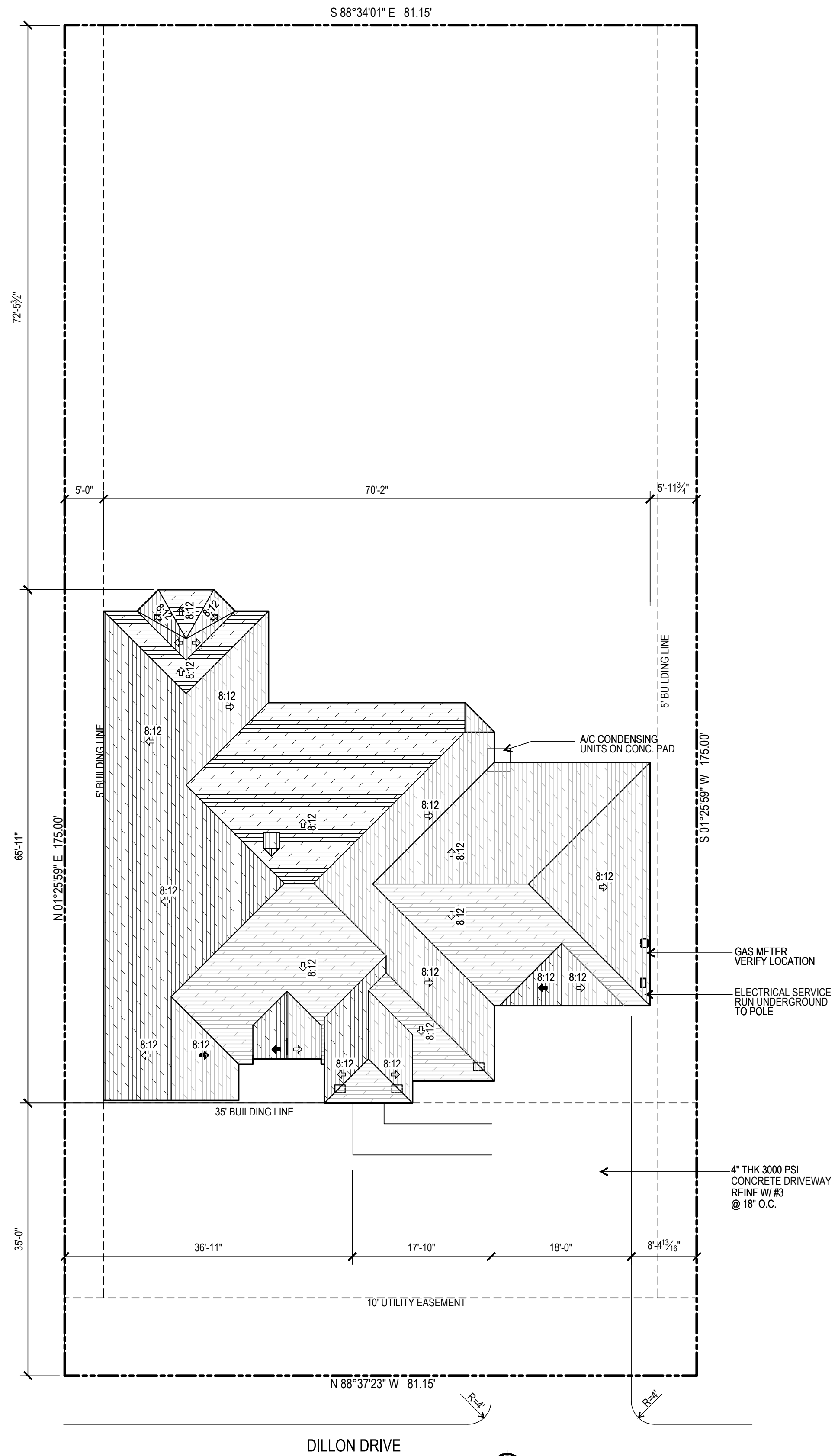

GENERAL NOTES:

- ALL ROOF PENETRATIONS (I.E. PLUMBING AND GAS VENTS, ETC.) ARE TO BE RESTRICTED TO THE REAR ROOF AREA ONLY. UNDER NO CIRCUMSTANCES SHALL THERE BE ROOF PENETRATIONS AT THE ROOF FACING THE STREET.
- ALL SITE WORK INCLUDING LOCATION OF TRASH DUMPSTER, TEMPORARY TOILET FACILITIES, TEMPORARY CONSTRUCTION FENCING, CLEARING PROCEDURES, GRADING AND DRAINAGE, ETC. SHALL BE IN ACCORDANCE WITH CITY OF HOUSTON REQUIREMENT/GUIDELINES.
- CONTRACTOR SHALL PROVIDE AND BE RESPONSIBLE FOR TEMPORARY UTILITIES TO THE CONSTRUCTION SITE.

1 SITE PLAN
3/32"=1'-0"

LEGAL DESCRIPTION
LOT 74, BLOCK 6, WOODLANDS OAKS, A SUBDIVISION IN MONTGOMERY COUNTY, TEXAS, ACCORDING TO THE MAP OR PLAT THEREOF RECORDED IN CABINET E, SHEET 258 THROUGH 268 OF THE MAP RECORDS OF MONTGOMERY COUNTY, TEXAS.



P.O. Box 131326
Spring, Texas 77389
210.336.5225 Mobile
281.789.7740 Phone
avalienciadesigngroup@gmail.com

© GLOBAL SKETCH GROUP
2012. ALL RIGHTS RESERVED.

The designers of GlobalSketchGroup are not, and do not represent to be, licensed architects. The designation Professional Building Designer (PBD) does not confer or imply any legal status in the State of Texas as a "registered professional". In Texas the practice of Commercial and Residential Design by a designer who is not a licensed architect is limited and permitted by exemptions to the Architect statute Chapter 1051. The building design works depicted herein are the sole property of GlobalSketchGroup and may not be constructed or used without its express written permission. No permission to modify or reproduce any of these building design works, including without limitation the construction of any building, is expressed or should be implied from delivery of preliminary drawings or unsealed construction drawings. Permission to construct the building depicted in sealed construction drawings is expressly conditioned on the full and timely payment of all fees otherwise due GlobalSketchGroup and, in the absence of any written agreement to the contrary, is limited to a one-time use on the site indicated on these plans.

SHEET TITLE:

SITE PLAN
FLOOR PLAN

SHEET NO: